

Harbor Area MARC / MAFCA

Founded in 1957. Torrance, California.
56 years of driving history!

The HarborLight Newsletter
was awarded the MARC
Newsletter Award of Excellence
2009, 2010, 2011, 2012

HARBORLIGHT



Harbor As getting ready for the trip to the Orange County Pancake Breakfast

Tours

After a busy May, we will have continue with a fun event at the **Henry Ford Picnic** put on by the **Downey Diamond Tread Chapter Model A Club**. This will be on **Sunday, June 23, 2103** in Santa Fe Springs. Elaine Pisu will have more details as we get closer. See you there.



Technical, Looking Ahead

If you have a good idea for a technical seminar, let our Tech Director, Jim Speights know. This could be as simple as checking wheel bearings or as complicated as changing timing gears. Let Jim know.



Upcoming Business Meeting

The May meeting will be **Friday, May 31st**. The meeting starts at 7:30 at WALTERIA clubhouse. Come early, help set up and talk to your Model A friends.



The June business meeting will be on **Friday, June 28th**. See you there!

Next Board Meeting



The next board meeting will be the **El Segundo Driving Museum** on **Tuesday, June 4th, at 7PM**. We'll discuss current status and future events. All members welcome.

Our awesome website is up and running!
Visit it at:
www.HarborAreaModelAClub.com

inside...

2	Monty's Message
2	Pancake Breakfast pictures
3	Birthday - Editor's Corner
4	Sunshine Status - Roster updates
4	Club merchandise
4	Local car gatherings
5	Business meeting notes
6	Tech Talk - How speedometer works

7	Touring with Elaine
7	Edelbrock tour pics
8	Wheels & Deals
8	Muckenthaler tour
9	Future Events of Interest
10-11	Our Advertising Friends
12	Officer List & Mailing Info



Monty's Message
A Note from our President
Monty Bates



An Active Year So Far.

First and foremost is a very special prayer for all the folks in Oklahoma...such incredible forces of nature. The folks in the know are predicting a nasty hurricane season this year, just to add to an already bad 2013. I forget how lucky we are to be in the South Bay.

Elaine Pisu has continued to raise the bar on fabulous tours and special events. May has been great & the folks from NCRG aren't back yet. We have certainly enjoyed two fantastic events and tours. The Edelbrock engineering staff and management were super friendly, and made us part of their celebrations. The "behind the scene" factory tour was outstanding. We sure had a great time at the 2013 Muckenthaler Motor Car Festival in Fullerton. WOW...we did our best to represent Henry's cars surrounded by some very beautiful and expensive show cars. We had great food, fellowship with other car crazy people and a beautiful day and no mechanical problems. Great tour!!!!

Mr. Drain Marshall joined me in attending the So Cal Regional Model A meeting on Saturday, May 11th. This group of area presidents gathers to plan events and link to our National organizations. Plans for the fall events are in works.

Thanks to all for your continuing attendance at dinner Monday nights. Hof's Hut's people are getting used to having thirty plus at one table...come on down. Looks like June is going to be another very busy month...Stay in touch!!!!

Be safe out there!

Monty

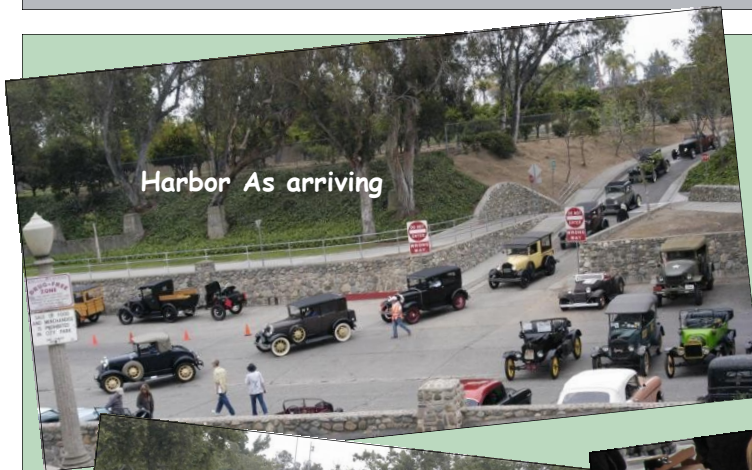

Harbor As arriving



The Harbor As had a great time at the OC Pancake breakfast

Ummm. . . Bacon, bacon, bacon



200+ Model As



Dr. Steve and Weeg



Sandy and Ron

June Birthdays

- 7 JoAnn Moore
- 13 Joan Gordinier
- 14 Frances Earhart
- 23 Barney Clayton
- 23 Andy Soto



June Anniversaries

- 4 Jeanne & Richard Parrish
- 5 Diana & Marty Murphy
- 7 Bill & JoAnn Moore
- 14 Kathy & Jim Valot
- 22 Greg & Frances Earhart
- 25 Willie & Darlene Duncan
- 26 Cliff & Teresa LeFall

Editor's Corner by Dick Wyckoff

A lot of fun this last month. OCs Pancake Breakfast, the Edelbrock 'Rev'ed Up for Kids' Tour, The Muckenthaler Concours. . . . Lots of interesting events. If you missed any of them, you missed a lot. I've tried to capture the event with my camera but there are others that take pictures, too. If you have some good ones, send them to me and I will try and get them in the HarborLight.

Changing the subject a little, we editors are always looking for articles of interest to put in the newsletters. There must be some interesting Model A stories waiting to be told. For instance: How long have you had your car? Was it your first car? Have you driven it on some great journeys? Was it a family car? Did you restore it yourself? Do you have before and after pictures? Did you take a neat picture at a club event? Email them to me, or if you have photos, I can scan them and put them in the newsletter. Either way, let me know.

I have been encouraging new members of the Harbor club to receive the HarborLight by **email**. I am also asking existing members to do the same. Just let me know your current email address. It's that simple. The club saves a little more than one dollar each month per email subscriber. I have an email distribution now of 39 people from the Harbor Club and 34 others. This is more than \$800 per year savings, **AND** it is **color!** You can print it out in B&W or color if you want, enlarge it, send it to your friends, or save it in your computer files. Again, just let me know your email address. If you want a sample email version, let me know also. I will send you one.

The newsletter is distributed to many other clubs locally and to other parts of the country. If you have an item for sale, let me know. I will put it in the 'Wheels and Deals' section. Thanks . . .



We took home The Breakfast Bacon!

Three members of the Harbor As got favorite car in the class awards. **Bobby and Phyllis De-Crescenzo** got the Best 30-31 Closed car trophy with his 30 Tudor Sedan, **Nita and 'Stoney' Stonehocker** got the Best Modified trophy with his newly finished speedster, and **Dick and Jan Wyckoff** won the Best 30-31 Open Car with their 30 Cabriolet. Great Job you all!

Harbor 'Sunshine Status' by Doris Marshall

Several of our members have lost loved ones this month. Our prayers and thoughts are with you in this difficult time.

Jan Wyckoff's brother, Don, passed away at age 93. A WWII vet of N. Africa and Italy.

Drain Marshall's brother, Robert, passed away at age 62.

Jack Gordinier's mother passed away at the young age of 96. A Torrance resident for many years.

Pat Yacklon's nephew also passed away.

Art Wagner's sister passed away late this month also.

Again, our thoughts and prayers are with all of you. May our departed family members rest in peace.

Saturday Morning Coffee Gathering

If you are looking for a little tire-kicking adventure on **Saturday** mornings between 7 and 9AM, check out the Caffeine Cruisers at the corner of Artesia Blvd. and Hawthorne, in Torrance, CA. Several of the Harbor Model A club members and other car enthusiasts of all car types meet to talk cars. There are some very nice autos and some nice people there, too! The address is 17400 Hawthorne Blvd., Torrance CA. Come on by, have a cup of Starbucks, and get your weekend started in true So. California style.



"Cruise at the Beach" Friday afternoon at Ruby's Diner:

Starting Friday, April 5th, Ruby's Diner 245 N. Harbor Drive, in Redondo Beach (by the pier) will host a weekly gathering of fun cars. This event can bring as many as 150 cars of all types. Classics, Concours, hot rods, antiques, sports cars, motorcycles, and Model As. Many Harbor Club members show their cars and enjoy a great meal in the diner. Check it out. Times are about **4PM to 7:30PM every Friday**. There is a nice raffle and trophies are awarded each week. Parking is free to participating cars. This event will continue all summer until October 25th, 2013. See you there.



2013 Membership, Roster and Club Items: by Ursula Schmidt

The new, updated 2013 Harbor phonebooks/rosters are available at all get-togethers. The first booklet is free to members. Additional copies are \$2. They are also available free of charge through e-mail. Club members that don't attend events can request a phonebook/roster by mail. Contact **Ursi Schmidt** at 310-539-5391.

Just a note: We regularly update the roster. If you have any address changes, phone number changes or email changes, let Ursi know.

Also available are embroidered ball caps with the club's logo. Available in many colors \$15. There are club T-shirts, pins, and 50th anniversary cookbooks still available, too. Please call **Jan Wyckoff** at 310-322-8863 to place your order.



New Club jacket info from Jan:

At the next two meetings, Jan will be collecting names of those who would like to order new club jackets. She will put together a sign-up sheet with the appropriate info on it. The jackets come with your name and the club logo on the front. Approximate price is \$35. Embroidery on the back is extra.

Business Meeting Minutes

Walteria Clubhouse

Date: April 20, 2013

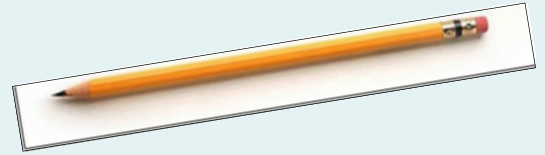

President: Monty Bates called the meeting to order at 11:25 AM.

Meeting held at Dick & Ursi's home.

Salute to the flag: Led by Jack Gordinier.

Recognition of Past Presidents: Present were: Drain & Doris Marshall, Pat Yacklon, Steve Preston and Dick Wyckoff.

Secretary: Minutes of previous meeting were approved.

Vice President: Tim Harrison said there would be no raffle. Instead, Pat Yacklon sold the 50-50 tickets.

Treasurer: Daffy Wagner reported a balance of \$7295.49.

Harborlight Editor: Dick Wyckoff needs articles or pictures within the next two days.

Webmaster/Historian: Monty welcomed Sue & Pat back from their trip. They are leaving again May 19th for the Calgary Stampede in Alberta, Canada. They expect to be gone for about three months. Jan Wyckoff will fill in as Secretary.

Membership: Nita & Todd Stonehocker signed up again. With the help of Dick Wyckoff, Ursi said a full size roster is available. Monty and everyone thanked Dick Lusk & Ursi for the use of their home again for this Safety Seminar.

Woman's prize: LeOra Combs Men's prize: Andy Soto

50-50: (Split in thirds) Winners: \$55 to Dot Knott, Georgette Avoian & the club.

Technical Director: Jim Speights announced there will be a generator seminar at Al's garage the end of May.

Sunshine: Rhoda is doing fine. Paul is holding his own. Bill Newell said Dorothy Wood has been feeling dizzy and did not attend today.

Tour Director: Next Sunday, April 28th is the OC Pancake Breakfast. Meet at Harbor Freight Tools at Hawthorne and Artesia at 6:45 AM and leave at 7:00 AM. May 18th there is a mystery tour. Details to be announced later. June 23th is the Henry Ford Picnic. Drain advised everyone to get their hotel reservations for the NCRG in Pleasanton May 24th-27th. Nita said coffee and donuts are served at the Back in the Day car sales lot on Avalon the third Sunday of the month.

Monty awarded the Thumb to Drain Marshall. His engine block cracked upon returning from the Henderson meet. Monty thanked Bobby D. for his record keeping during the seminar.

Advertising: Amy Knott said everything is fine. Torrance Transmission works on Model A's.

Monty thanked everyone for the attending the Monday night dinners at Hoff's Hut.

Meeting adjourned at 12:00 PM.

Next Meeting: Friday May 31th.

Respectfully submitted, Secretary, Pat Yacklon

Chewy Lemon White Chocolate Chip Cookies

Yield: about 3 dozen cookies

Ingredients:

- 1 1/2 cups flour
- 3/4 teaspoon baking soda
- 1/2 teaspoon salt
- 3/4 cup (1 1/2 sticks) butter, softened
- 1/2 cup packed brown sugar
- 1/4 cup sugar
- 1 large egg
- 1 tablespoon lemon juice
- 2 cups white chocolate chips
- Zest from one lemon



Instructions:

1. Preheat oven to 375° F.
2. Combine flour, baking soda and salt in a small bowl.
3. Beat butter, brown sugar and granulated sugar in a large mixing bowl until creamy.
4. Beat in egg and lemon juice; gradually beat in flour mixture.
5. Stir in white chocolate chips and lemon zest.
6. Drop by rounded tablespoon onto parchment-lined baking sheets.
7. Bake for 7 to 10 minutes or until edges are lightly browned.
8. Cool on baking sheets for 3 minutes; remove to wire racks to cool completely.

Technical Talk

IT MEASURES YOUR MILES

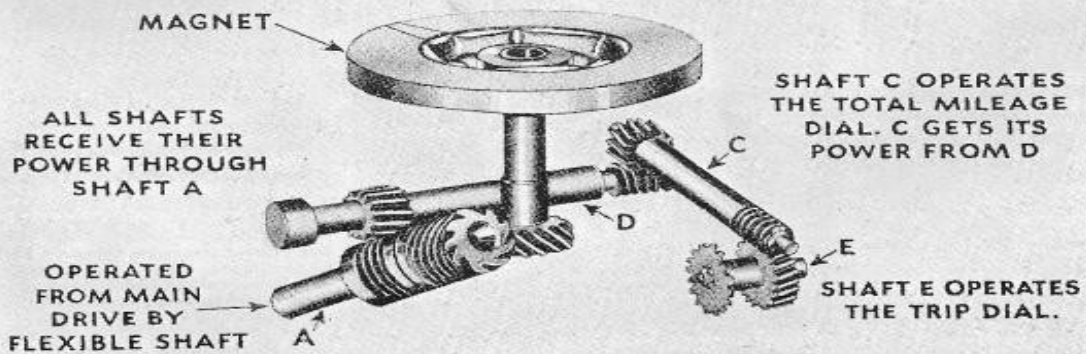
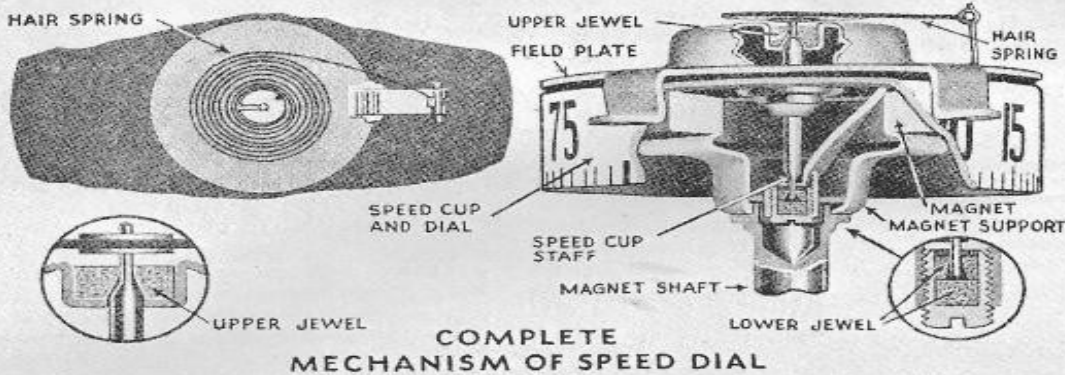
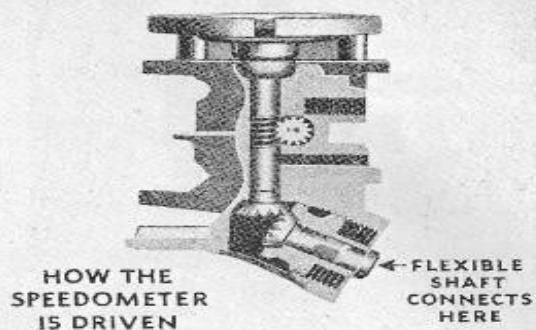
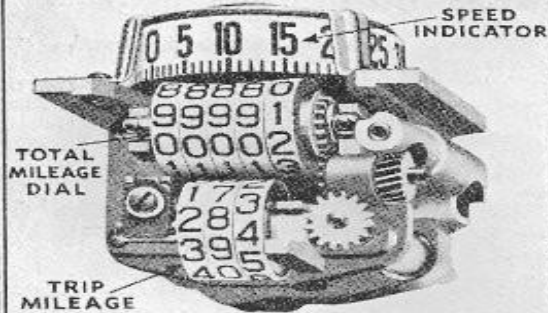

A speedometer is a device used on motor vehicles to indicate mileage. Most speedometers have attachments which indicate the total number of miles traveled, miles per hour and mileage per trip. This speedometer, which resembles the "A", is operated through the action of a revolving magnet driven by a flexible shaft driven from a gear coupled to the drive shaft. Though not required by law, speedometers are almost a necessary part of the equipment of a motor vehicle, since all communities have speed laws which must be obeyed.

Thanks to the *Model A News*, July-August 1967



MAFFI Museum
Brick photos
By
Richard Parrish
May 2013

Tours and More Tours

By Elaine Pisu, Tour Director

Since our last newsletter the Harbor A's have been very busy. As always we had a great time at the OC Pancake Breakfast. We came away with 3 car trophies, Bobby and Phyllis DeCrescenzo, Toad and Nita Stonehocker, and Dick and Jan Wyckoff. Congratulations!!

On May 4th, 18 members had a wonderful tour of the Edelbrock facility. We had 6 Model A's and 4 moderns. It was amazing to see what the facility makes right in our own backyard. The following day Don Knott entered his beautiful yellow hot rod in Edelbrock's 'Rev'ed Up 4-Kids' car show. This is a show that you definitely must see next year.

May 19th we joined the Horseless Carriage club in Fullerton. We met just off the freeway and entertained several Asian tourists and their cameras with some great Model T's and lots of Model A's. We traveled together to the Fullerton City Hall for coffee and donuts and then paraded to the Muckenthaler Concourse d'Elegance. We had a great time with 7 Model A's and 2 moderns making the trip. It was a wonderful and relaxing day. Maybe that's because of the \$5 Bloody Mary's, live entertainment and a fabulous display of cars. We had VIP parking, a nice lunch and will definitely try to go again next year.

On Sunday June 23rd we will be headed to the Henry Ford Picnic in Santa Fe Springs being hosted by the Diamond Tread club. Please sign up at our meeting on May 31st. Lunch will be \$10 and I will collect at our meeting. We will be meeting at Harbor Freight at Hawthorne and Artesia at 9:00am, leaving at 9:15.

BE SAFE AND KEEP HAVING FUN WITH THOSE "A's"

Lots to see at the Edelbrock Manufacturing Plant in Torrance CA

Thanks to the efforts of our tour director, Elaine Pisu, we were able to get a tour of the manufacturing facilities of the Edelbrock Corporation in Torrance Ca. This is the same Edelbrock that make the famous racing equipment seen all over the world. They are celebrating 75 years as a producer of outstanding specialized performance equipment for many different automobiles. We got to see the whole process from computer design to finish machining. A great tour for the club.



Wheels & Deals:

For Sale:

- **1930 Model A Ford Pickup "Pony Express" Mail Delivery Vehicle.** Touring Engine, 12v, Weber downdraft, 5-speed tranny, hydraulic brakes, 2-yr old Firestone tires, fresh radiator, gauges, tach, 12v outlet for GPS or radio. Other extras. Contact Steve Newton 310-837-3026. \$13,500.

Wanted:

- **1928 Ford project coupe.** 1929 is my second choice. It does not have to be complete. I will find the missing parts. Jay Skinner (562) 426-5478 Long Beach
- **Used Christmas and greeting cards.** (Complete cards please). We will recycle them. Ursi (310) 539-5391 and Doris (310) 378-5061.

2013 Muckenthaler Motor Car Festival

An easy 25 mile trip on the freeway where the Harbor As joined 25 other same-era cars for a drive to the Concours in Fullerton.



Tour cars



Our As on display



Muckenthaler Mansion



Monty says 'Hello'

Astro-Auto-Electric

ALTERNATORS*STARTERS
SERVING SOUTH BAY FOR 30 YEARS
SPECIALIZING IN ELECTRICAL PROBLEMS

310 325.1777



1926 W. Lomita Blvd. • Lomita CA 90717

MARIVEL COSTANZA
REALTOR® - BROKER - NOTARY PUBLIC
Making a Difference One Home At A Time



KELLER WILLIAMS
REALTY

Cell: (310) 413-0658
Fax: (310) 787-8525
Marivelpcostanza@aol.com
WWW.MARIVELCOSTANZA.COM

Charlie Cool's Auto Repair

Specializing
in Auto
A/C



24406 Crenshaw Blvd
Torrance Ca 90505

310-325-3504

AUTOPLEX INC

INDEPENDENT REPAIR
IMPORT - DOMESTIC



FACTORY TRAINED
MASTER CERTIFIED
TECHNICIAN

DANIEL GOYA
OWNER

16015 S. Western Ave.
Gardena CA. 90247
310-323-0969

Lots of Car Events of Interest for 2013

- June 2nd (Sun) **43rd Antique Nationals Drag Race and Car Show.** Irwindale Drag strip, 500 Speedway Drive, Irwindale CA 91706. Nostalgia drag races. More info: Dan at 626-827-4004.
- June 8th (Sat) **7th Annual Hubley Derby Day.** Woman's Club of San Bernardino. Sponsored by the Pomona and Paradise Valley A Clubs.. 9am to 3:30. More info and registration: 909-227-1853.
- June 22nd (Sat) **'Back in the Day' Car Show.** 21126 S. Avalon Blvd., Carson CA 90745. 10am to 3pm. Free
- June 22-23 (Sat-Sun) **44th Swap Meet.** Riverside Model T Club. Western Little League Regional Headquarters, 6707 N. Little League Drive, San Bernardino CA 92407. Info: Don Kirtley 909-754-2360.
- June 23rd (Sun) **Annual Henry Ford Picnic** sponsored by the Downey Diamond Tread Chapter. Heritage Park 12100 Mora Dr., Santa Fe Springs CA 90670. 10Am to 3PM. \$10/person. BBQ lunch
- June 29th (Sat) **16th Annual Orange County Model T Car Club Swap Meet / Car Show.** 6AM to 2PM. El Dorado High School, 1651 Valencia Ave., Placentia CA 92870
- June 30th (Sun) **Breakfast Club Cruise-in** at the Peterson Museum the last Sunday of every month, 9am - noon. Get free parking and 2 for 1 admission to the museum.
- July 12-13 (Fri-Sat) **59th Annual Long Beach Model T Club Swap Meet.** Los Alamitos Race Course, 4961 Katella Ave., Los Alamitos CA 90720. Admit: \$6 per person. 7AM to 7PM Friday, 7AM to 4PM Saturday. Info: Jeff Hood 562-597-5936
- July 26-28 (Fri-Sun) **Wings 'n Wheels** in Solvang. Save the date. Fun weekend. Sign up before June 18th.
- August 11th (Sun) **6th Annual Wounded Warrior Car Show.** WyoTech's Campus, 2161 Technology Place, Long Beach CA. Info: 310-343-9634. Email: threenthtre@yahoo.com 9am to 3pm
- September 14th-15th (Sat-Sun) **21st Palos Verdes Concours d'Elegance.** Trump National Golf Course. Tickets and info: 866-522-7746 or visit www.pvconcours.org
- September 14th (Sat) **11th Annual All Ford Car Show** and Swap Meet in Old Town Orcutt, more info to follow.
- September 29th (Sun) **52nd Annual Antique Car Swap Meet.** Paradise Valley Model A Club. Western Little League Regional Headquarters 6707 N. Little League Dr., San Bernardino CA 92407. Info: John Bensen 909-875-4545.
- October 12th (Sat) **The 3rd Annual Model A Ford Roundup** hosted by the Santa Maria Chapter. We will have a Santa Maria Style BBQ, Car Games, and a raffle. Price \$5 per head. Please come. A good time will be had by all. More details to follow.

Check out our new advertisers

BODY WORK & PAINT



323.519.2079

POLISH
DETAIL
FIBER GLASS
RIM PAINT
INTERIOR AND
EXTERIOR WASH

and J

424.224.0014

UPHOLSTERY WORKS



**Complete Interiors, Insert
Replacement, Carpet,
Head Liner, Convertible Tops.**

**25 Years Experience
Good Price**

Ask for: **J.R.**
(424) 571-0224

TORRANCE TRANSMISSION SERVICE

Drain Marshall says:
Ask about their
Model A
Lube, oil change
Special

ERIC BAILEY

Phone: (310) 378-9217

24009 S. Hawthorne Blvd.
Torrance, CA 90505



KAREN'S GIRL TALK

16803 South Prairie Avenue
Lawndale, CA 90260

Phone: (310) 370-2916

All Beauty Services
by Karen



Patricia Tucker
formerly Patricia's Doll House
Stuffed Toy & Doll Repairs
(310) 835-2687

lotsadolls@ca.rr.com

ARIZONA MODEL A, L.L.C.

- NEW PARTS
- USED PARTS
- SERVICE
- RESTORATION
- HOURS: TUES-FRI 9-12, 1-5
SAT & EVES BY APPOINTMENT



SAMUEL P. GUTHRIE

15838 S. GILBERT RD., CHANDLER, AZ 85225
(480) 782-0266

Awards • Plaques
Medals • Ribbons
Laser • Engraving



A&E TROPHIES AND ENGRAVING

24519 Narbonne Ave. Lomita, CA 90717

SANDRA HEIN

Ph: (310) 539-1033
Fax: (310) 539-9970

Mike's "A" Ford-able Parts

Mike Butcher



124 Model A Drive, Maysville, GA 30558

email: mike@mikes-afordable.com - www.mikes-afordable.com

Fax: 706 652 2492 - Phone: 706 652 3866

1 888 TRY MIKE (879 6453)



Specialising in 1928 - 1931 Model A Ford Parts



RYAN'S HARDWOOD FLOORING

Lic # 843173

CUSTOM INSTALLATIONS

PREFINISHED
UNFINISHED
ENGINEERED
CUSTOM DYES & STAINING
HAND DISTRESSING
TRIM & BASE MOLDINGS

REFINISHING & REPAIRS
INLAYS
BORDERS
MEDALLIONS
CUSTOM FURNITURE

(310) 722-3348



222 West 8th Street • San Pedro, CA 90731 • Tel 310.707.2207



Antonio y Maria
Velazquez

Tel: (310) 326 - 7635

Fax: (310) 326 - 4468

email: lavlaz1036@aol.com
www.firstclassembroidery.com

LUIS LOYOLA

Certified LeBaron-
Bonney Installer



310-225-6889

CONVERTIBLE TOPS • UPHOLSTERY

1859 W. 169th STREET • GARDENA, CA 90247
lai212@sbcglobal.net • www.loyolautointeriors.com

The *HarborLight* is a monthly publication for the Harbor Area MARC/MAFCA. All articles or want ads must be received by the 15th of each month in order to appear in the following month's publication. Neither the *HarborLight* and its staff, nor the Harbor Region of the Model A Restorer's Club Inc. and Model A Ford Club of America, Inc. will assume any liability for errors or omissions, or for any liability or resultant damages for products, opinions or services listed herein. Some information contained in our newsletter has been reprinted from other newsletters; we thank and acknowledge them. Editor

SNAX

Home of the original **SUPER BURGER**



30 YEARS SERVING YOUR
BREAKFAST AND BURGERS

4535 Sepulveda Blvd.
Torrance, CA 90505

Tel: (310) 316-6631

EARLY FORD STORE

Specializing in Rare Parts and Accessories for
Early Fords 1928/1972
Passenger Car & Pick-Up

of California

www.earlyfordstore.com



Bill McGrath
San Dimas, CA 91773
108 W. Bonita Ave.
Tel: (909) 305-1955
Fax: (909) 305-1953

Proud printer of the HarborLight

STUDIO PRINTING



446 Main Street
El Segundo, CA 90245

Edward Su
ed@studioprinting.net
www.studioprinting.net

310 ♦ 333 ♦ 8989
fax 310 ♦ 333 ♦ 8986
cell 310 ♦ 292 ♦ 3219

VELLIOS



AUTOMOTIVE MACHINE SHOP

4625 Manhattan Beach Blvd.
Lawndale, CA 90260

(310) 643-8540

Lic#496791

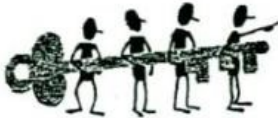

INDUSTRIAL LOCK and SECURITY

COMMERCIAL • RESIDENTIAL • AUTO
LOCKS SERVICED & INSTALLED
KEYS MADE • SAFES • ACCESS CONTROL
BONDED & INSURED

24 hr. EMERGENCY SERVICE
401 Main Street
El Segundo, CA 90245
FAX (310) 322-3627
(310) 322-3252

ELYSE BEARDSLEY

BRATTONS ANTIQUE AUTO PARTS



1606 BACK ACRE CIRCLE
MOUNT AIRY, MD 21771
Order # 800 255-1929
Web: brattons.com

FREE 194 page illustrated MODEL A parts catalog
Catalog contains 3,200 Model A parts with full
descriptions and Picture of each part.
Supplying Quality by using over 90% U.S. parts
Serving the Model A restorer with parts since 1977

MB RENTALS

Studio Equipment
Lights and Fixtures



Drain Marshall
Home: (310) 378-5061
Cell: (310) 612-3361

Vintage and Classic Car

Mohr's

Upholstery & Restorations

Specialty in Diamond Tufting
Rag Tops
mohrscarrestoration@yahoo.com

Off: 626-969-1607 /
Bill 626-484-7476
Chris 626-428-4935

228 S. Motor Ave., Azusa, CA 91702



H & H

Antique Ford Engine Rebuilding

Max Herman

4451 Ramsdell Avenue
La Crescenta, CA 91214
www.handhantique.com

Tel: (818) 248-2347
Fax: (818) 248-0161

PEPBOYS AUTO

Parts, Service and So Much More





3124 Sepulveda Boulevard
Torrance, CA 90505 • (310) 326-3002
Fax: (310) 326-2007 • Store #658
e-mail: mng0658@pepboys.com



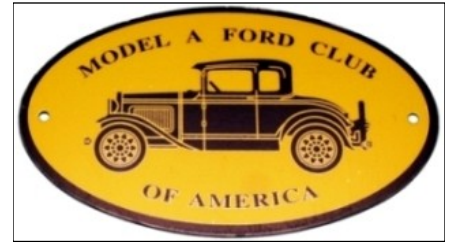

For MARC info and membership, see www.ModelARestorers.org



For MAFCA info and membership, see www.MAFCA.com

The Harbor Area A's meet monthly on the last Friday of every month at the Walteria Park Clubhouse, located at 3855 W. 242nd St. in Torrance, California. Meetings begin at 7:30 PM (The park is located about 1-1/2 blocks west of Hawthorne Blvd. and one block south of Pacific Coast Hwy.) We'd like to invite all interested parties, even if they don't own a Model A Ford, to come and join us. Our goal is to educate the public about Model A Fords and have fun while doing it.

2013 Board of Directors:

President:

Montelle Bates III (310) 516-0468

Email: BatesX3@aol.com

Vice-President:

Tim Harrison (310) 318-5920

Treasurer:

Daffy Wagner (310) 374-6113

Secretary:

Pat Yacklon (310) 782-0082

Tour Director:

Elaine Pisu (310) 793-1789

Technical Director:

Jim Speights (310) 675-2243

Appointed Officers:

Membership:

Ursula Schmidt (310) 539-5391

Historian:

Sue Hankins (310) 782-0082

Sunshine Secretary:

Doris Marshall (310) 378-5061

Advertising:

Amy Knott (310) 327-6559

Refreshments Coordinator:

Georgette Avoian (310) 371-5732

Tools:

Bob De Crescenzo (310) 540-3690

Appointed Officers:

Merchandise:

Jan Wyckoff (310) 322-8863

Sergeant-at-Arms:

Jack Gordinier (310) 328-7333

Webmaster:

Sue Hankins (310) 782-0082

www.HarborAreaModelAClub.com

HarborLight Editor:

Dick Wyckoff
337 Lomita St
El Segundo Ca 90245
Phone: (310) 322-8863

E-mail: Janndick@earthlink.net



The HarborLight

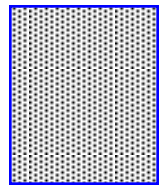

From:
Harbor Area MARC/MAFCA
Dick Wyckoff, Editor
337 Lomita St.
El Segundo CA 90245

June 2013



You know it's hot when

Enjoy your summer.
Stay cool!

TO: